

Линейни размери с непосочени допуски в mm					
ISO 13920	2-30	30-120	120-400	400-1000	1000-2000
B	±1	±2	±2	±3	±4
Permissible deviations for basic size range /mm/					

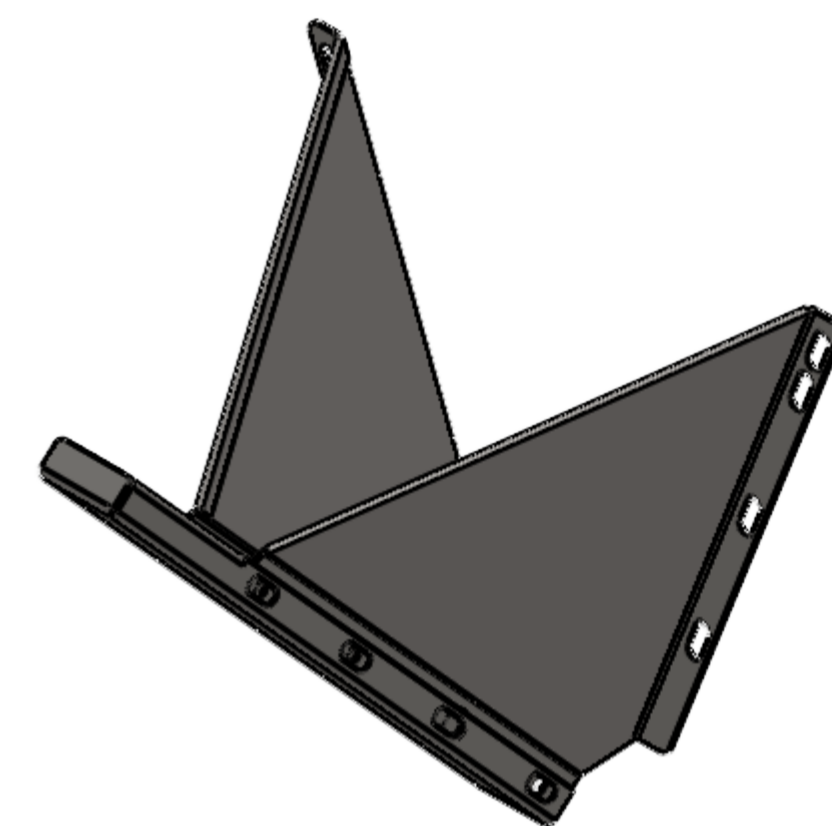

EDELSTAHLTRÄNENBLECH CS8 / R10

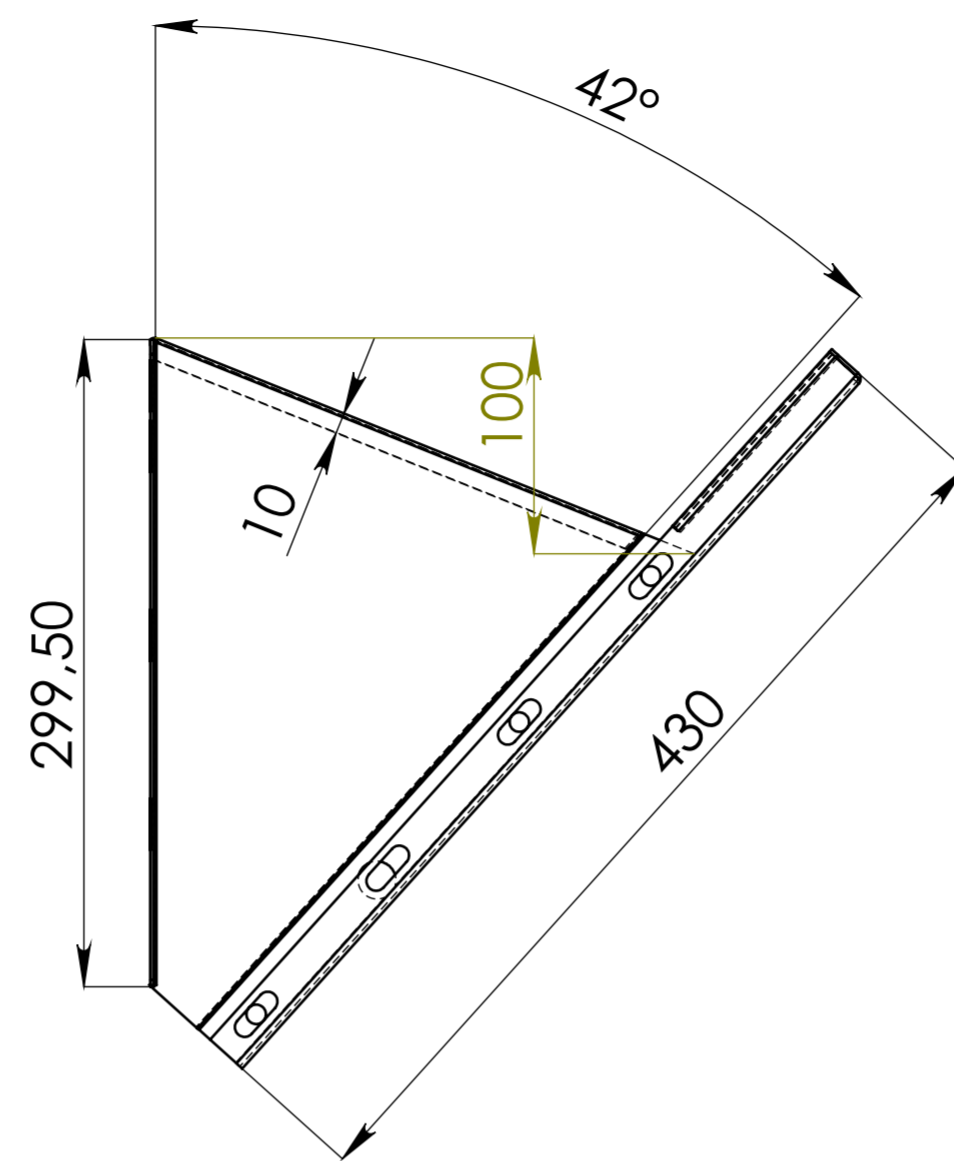
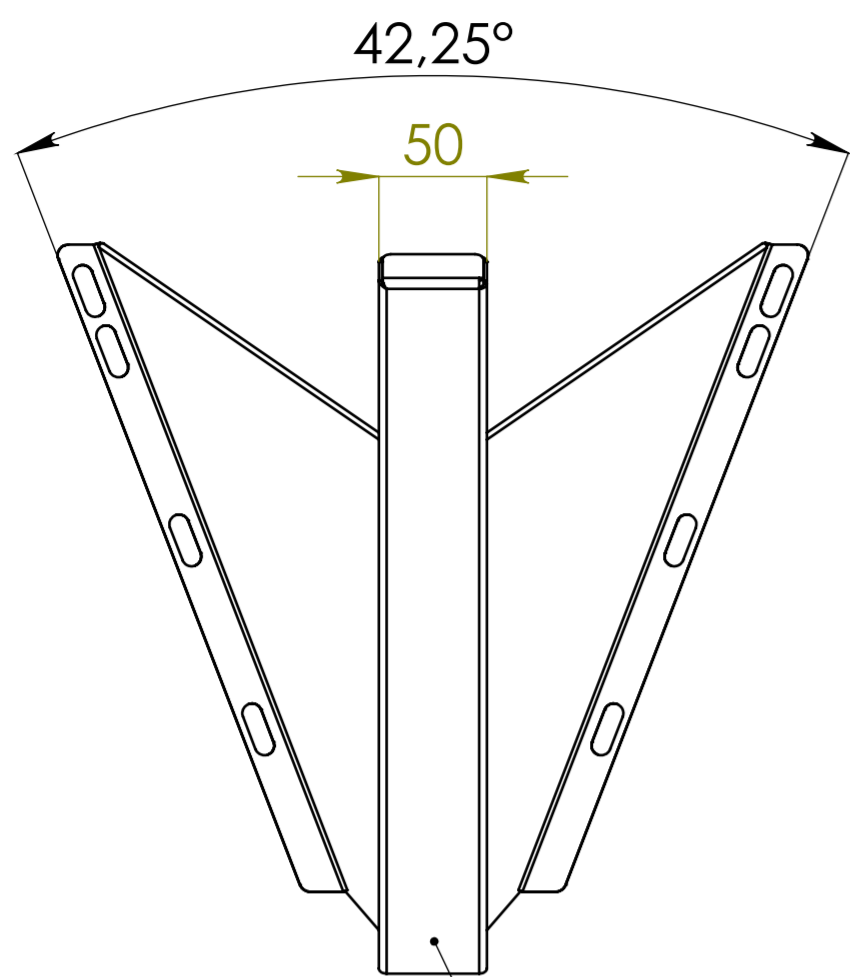
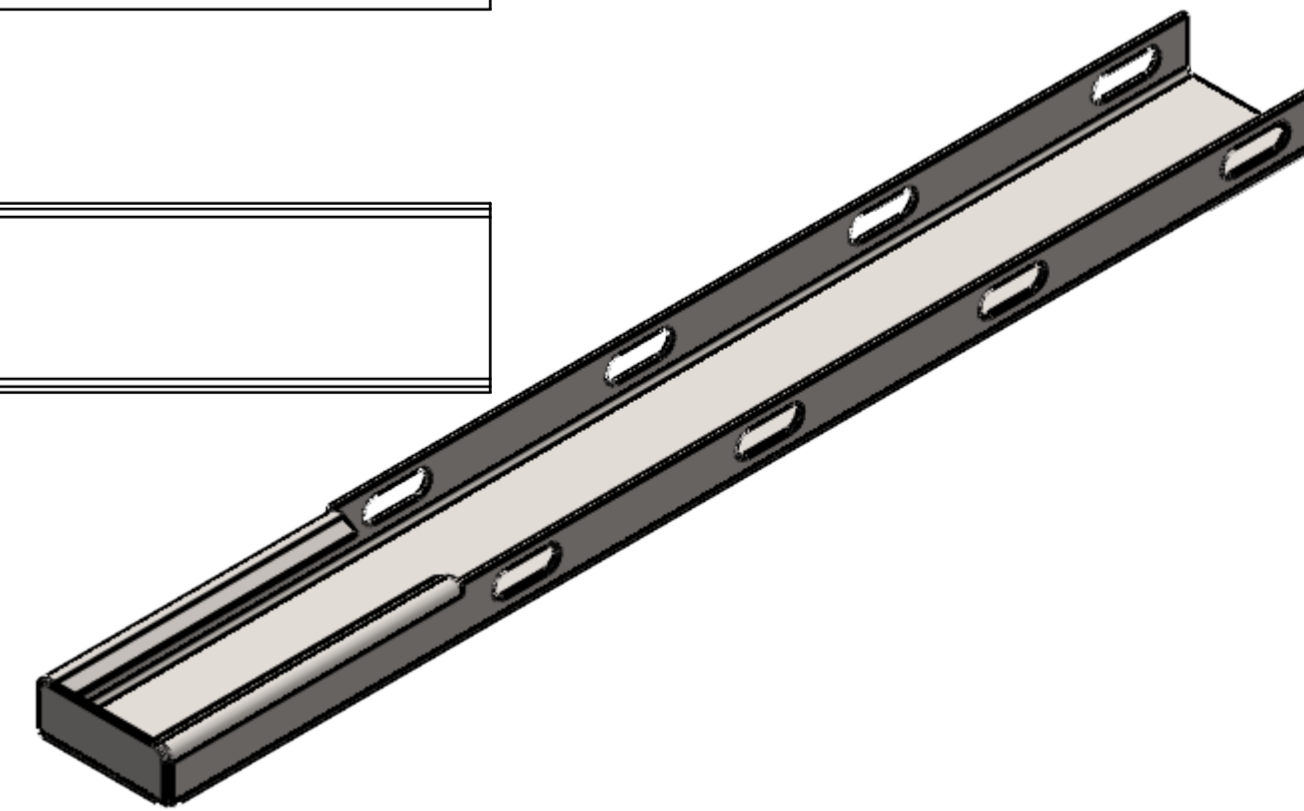
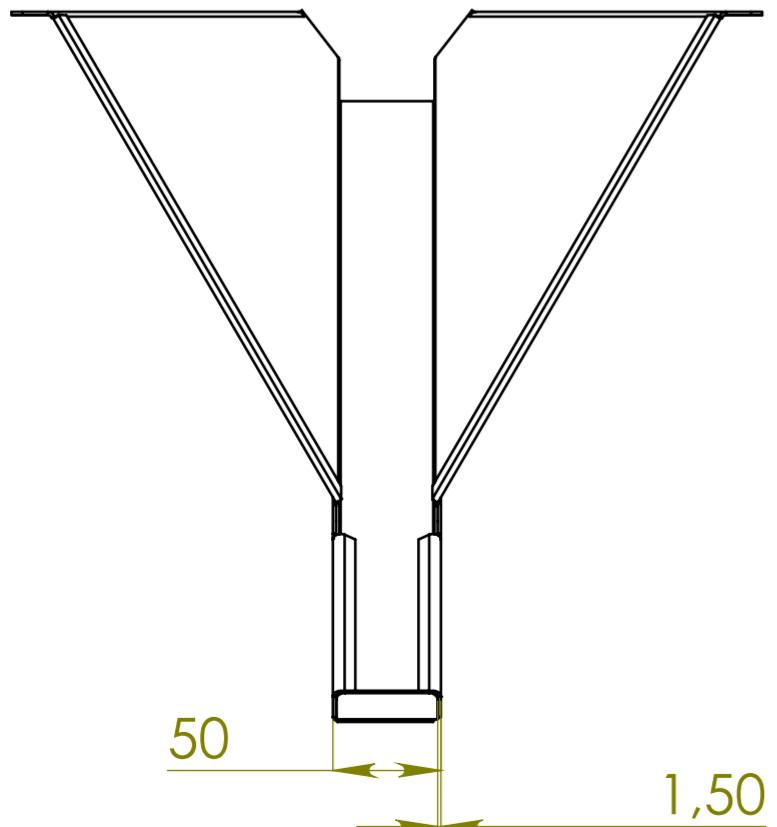
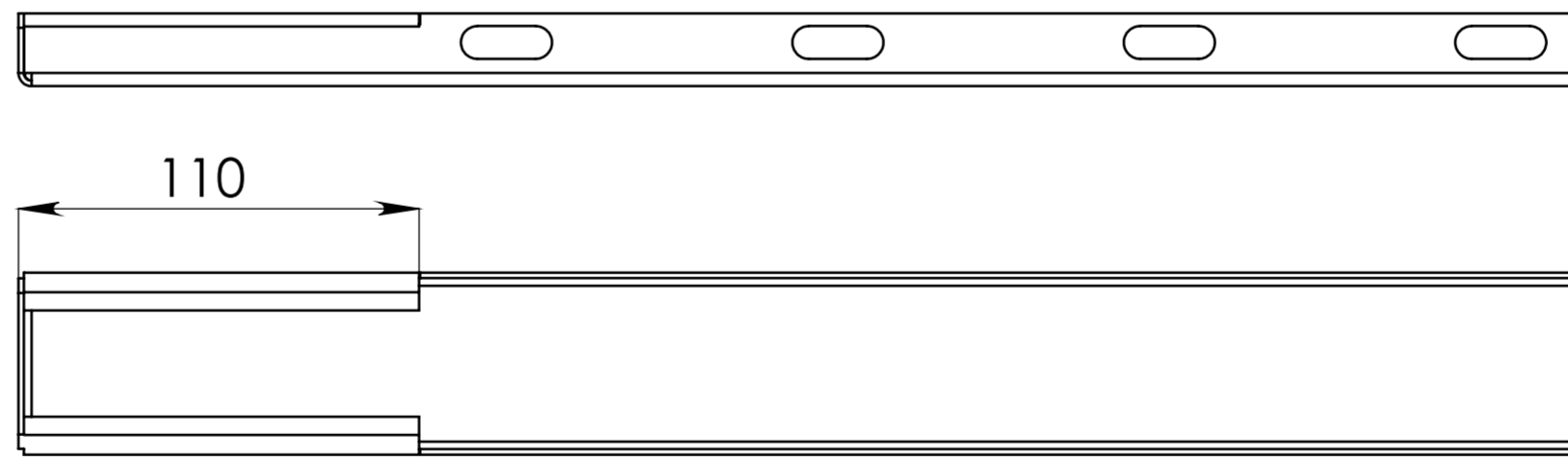
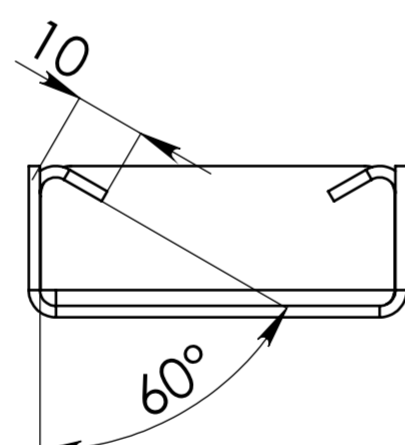

DRAWN NAME: Hr.Zhulev	FINISHDATE: 10 септември 2024 г.	Note:	
MATERIAL: 1.4301/X5CrNi18-10	Weight: 1.85 kg.		
DWG NO. 50675-450			

rev.B